

DESCRIPTION

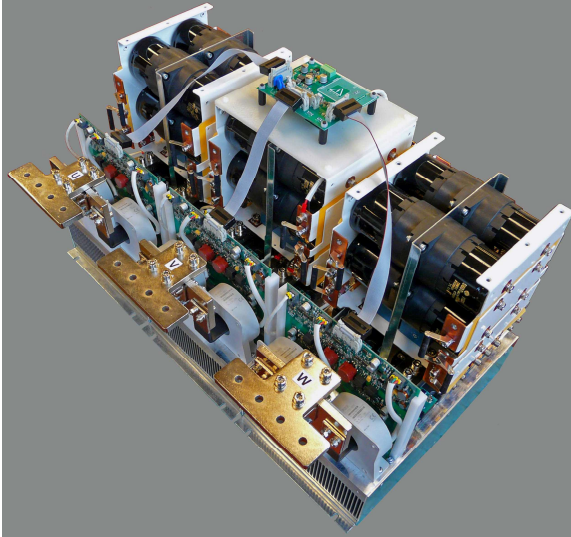

625 kW IGBT modular Stack. Easy to assemble with different configurations L,H,S.

- V_{SUPPLY} 24V.
- $V_{BUS(MAX)}$ 800 V_{DC}.
- V_{BUS} measurement.
- Internal IGBT measurement.
- 3 phases current measurement
- Connection with control card with 26_{PIN} flat cable.
- Capacitor bank 33.600 μ F
- Double DC connection per module.
- Output to phases through screws
- High efficiency heatsink.
- 100% fully electrically tested in production
- IGBT Infineon FF1400R12IP4
- IGBT Driver Dutt design

Considered Area	Dimensions _(mm) (Without fan)			Weight _(kg)
	Height	Width	Length	
Total necessary Area	415	735	490	32x3=96Kg.
Heatsink	98	240	360	

FREQUENCY-CURRENT(RMS) & FREQUENCY-CONSUMPTION

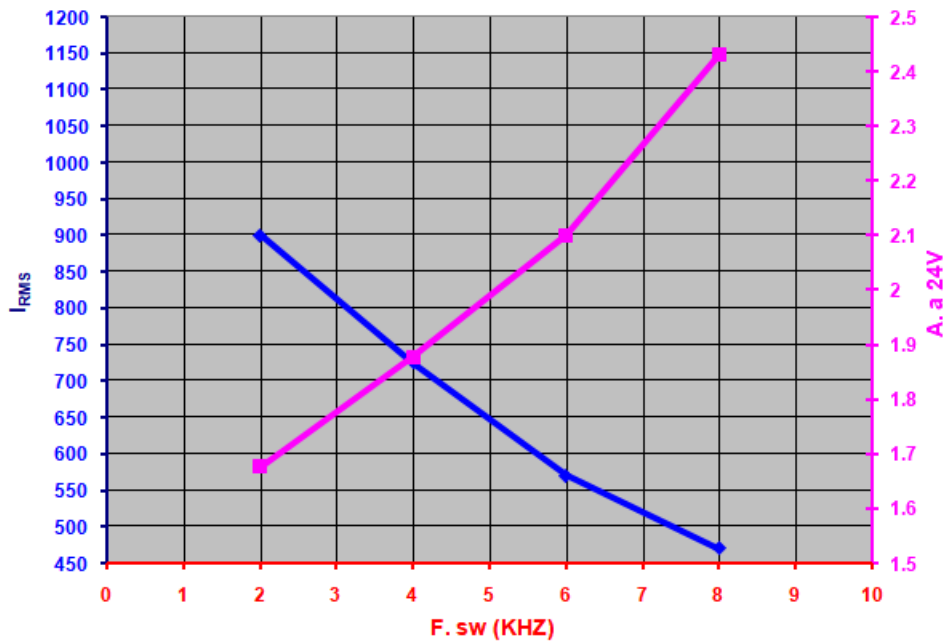

(V_{BUS} =560V, $T_{AMB.}$ =40°C, F.out=50Hz, FanQK10A-2DH68FK, Pressure_{ATM}=1010mbar)

INF2801

APPLICATIONS

- Motor control
- UPS
- Solar inverter
- Energy Storage
- Oil and gas pumps

TECHNICAL DIAGRAM

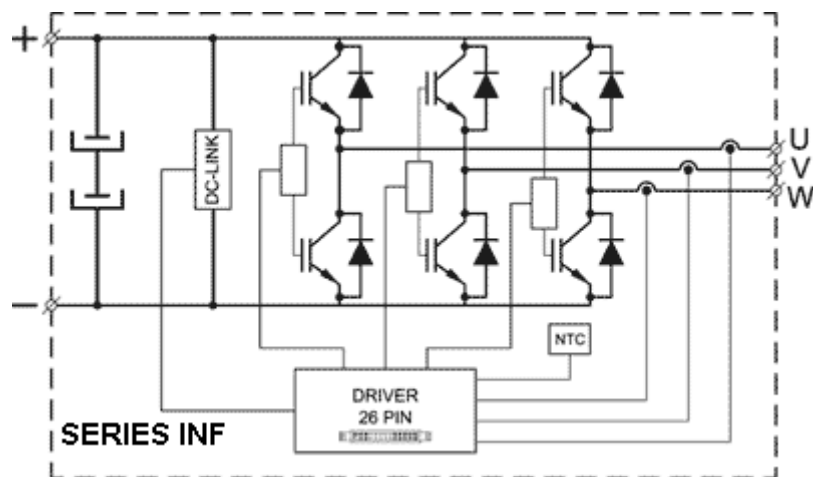

CUSTOMIZATION

All modules are 100% designed and manufactured in our facilities in Guipuzcoa(Spain). Power stacks (including drivers) or their respective control systems can be adapted according to the application.

Each project is different, please consult our technical team dutt@dutteletronics.com

OPTIONAL CONTROL

All Dutt power stacks are compatible with any control system (26PIN flat cable).

Dutt also design control and software solutions fully compliant with their power stacks.

The power stacks control may be optionally performed by the inverter control board Dutt 5000, designed especially for applications with grid regeneration or for individual control or motor/pump.

For applications that require simultaneous and precise control of multiple motors or pumps, the MTC 4031 control board is highly recommend. This is capable of controlling with the highest precision, DC, asynchronous and brushless motors.

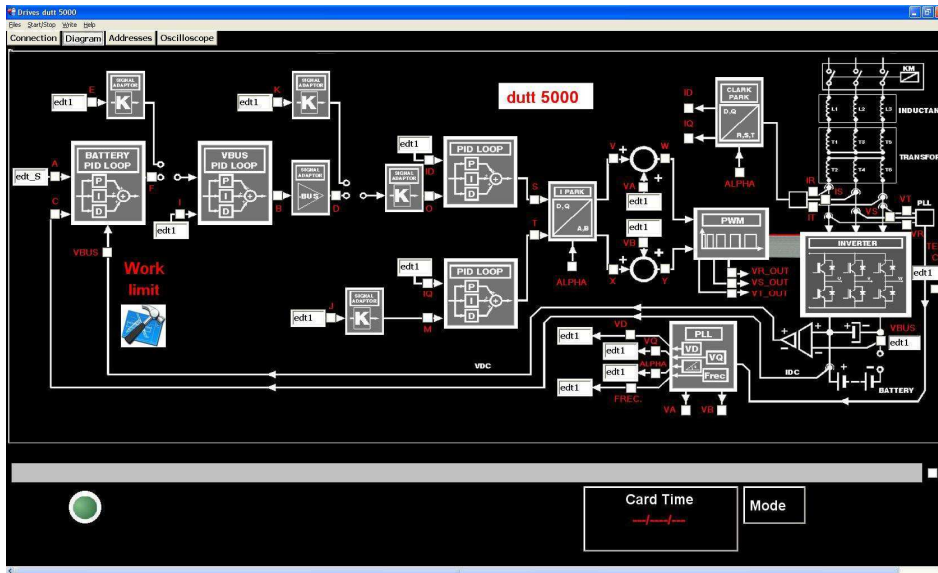

Dutt5000 Control panel

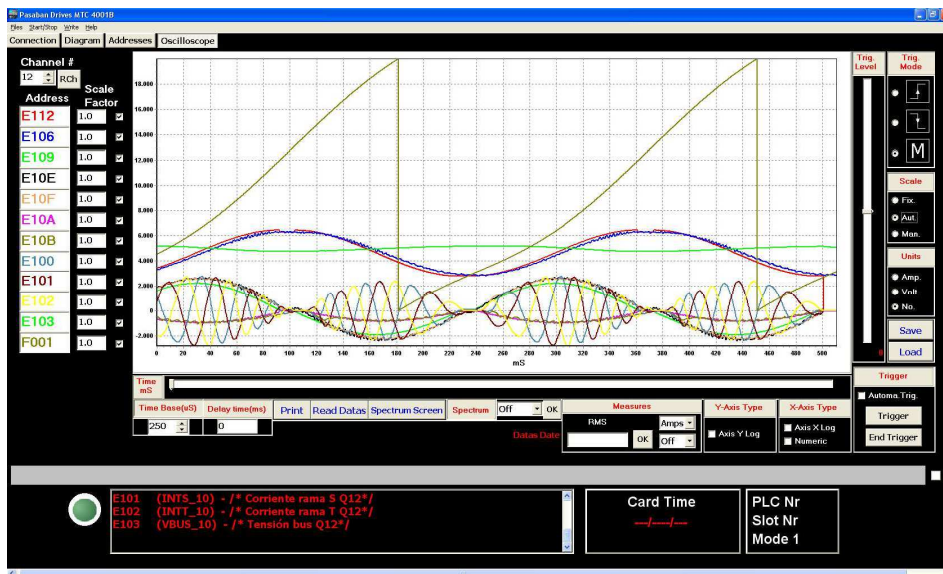

MTC4031 Oscilloscope panel